



Packaging machines



User manual

www.audion.com

Continuous Sealer

D 552 AVT

D 552 AVT ENG Rev.01

All rights reserved.

No part of this publication may be reproduced and/or published by means of print, photocopy, or in any other way, without prior written permission from Audion Elektro BV.

Audion Elektro BV reserves the right to modify the machine and/or change the operating manual without prior notice.

Audion Elektro BV is not liable for any damage caused by specifications deviating from the standard version.

Although this operating manual was compiled with the utmost care, Audion Elektro BV does not accept any liability for any mistakes it may contain and/or the consequences of any incorrect interpretation of its contents.

Audion Elektro BV is not liable for any damage or problems resulting from the use of parts other than original parts. If this operating manual does not provide instructions for certain repairs, settings or maintenance, please contact your dealer or Audion Elektro BV.



Please read this operating manual carefully before using the sealer or carrying out maintenance on it.

The sealer is part of the Audion product range. We also provide:

- Impulse sealers.
- Heat sealers.
- Continuous sealers.
- Vacuum sealers.
- Vacuum chambers.
- Crimping machines.
- Validatable sealers.
- Form, fill and seal machines.

Since its inception in 1947, Audion has gained a lot of experience and expertise with a wide variety of sealing and packaging machines. Our solutions for packaging problems are unique. Our many years of experience together with our modern production, assembly and testing methods ensure that our packaging machines meet the highest quality standards. We can also customise the machines according to your specific requirements.

Audion is the right supplier for a packaging machine that is geared to your requirements.

Contents

1	Introduction	6
1.1	Manufacturer	6
1.2	Machine type plate	6
1.3	Warranty conditions and liability	7
2	Safety	8
2.1	Symbols used in this manual	8
2.2	User	9
2.2.1	Operating personnel	9
2.2.2	Maintenance personnel	9
2.3	Safety instructions	10
2.3.1	General safety instructions	10
2.3.2	What to do in case of fire	11
2.3.3	Use for special applications	11
2.4	Safety provisions	12
2.5	Safety symbols.	12
3	Installation	13
3.1	Unpacking the sealer	13
3.2	Placing the sealer	13
3.3	Connecting the sealer	14
3.4	Adjusting the sealer	15
3.4.1	Adjusting the height of the sealing unit	15
3.4.2	Adjusting the horizontal position of the conveyor belt	15
3.4.3	Adjusting the height of the conveyor belt.	16
4	Description of the sealer	17
4.1	Function	17
4.2	Overview of the sealer.	17
4.3	Control panel	18
5	Operation	20
5.1	Preparing the sealer for production	20
5.1.1	Switching on the sealer.	20
5.1.2	Setting the sealing temperature and speed.	20
5.1.3	Switching on the heating, the cooling and the blower	21
5.1.4	Starting the sealer	22
5.2	Sealing	22
5.3	Stopping the sealer (STANDBY mode)	23
5.4	Emergency stop	24

5.4.1	Restarting after an emergency stop	24
5.5	Switching off the sealer completely	24
6	Troubleshooting	25
7	Maintenance	27
7.1	Maintenance schedule	28
7.1.1	Daily maintenance	28
7.1.2	Weekly maintenance	28
7.1.3	Annual maintenance	28
7.2	Switching off the sealer and opening the protective cover	29
7.3	Replacing the PTFE belts	30
7.4	Replacing the V belts	32
7.5	Adjusting the V belts	32
7.6	Replacing the heating elements	33
7.7	Adjusting the pressing force of the heating blocks	35
7.8	Adjusting the pressing force of the press rollers	35
7.9	Adjusting the pressing force of the cooling plates	36
7.10	Adjusting the pressing force of the after-press rollers	36
7.11	Adjusting the tension of the conveyor belt	37
8	Disposing of the machine	38
8.1	Directive 2002/96/EC	38
8.2	Correct disposal for reuse	38
Annex 1	Technical information	39
A1.1	Dimensional drawing	39
A1.2	Technical information	40
Annex 2	Electrical Diagram	41
Annex 3	Spare parts	44
A3.1	Consumables	44
A3.2	Exploded views	45
Annex 4	Log	55
A4.1	Maintenance log	56
Annex 5	CE declaration	57

1 Introduction

1.1 Manufacturer

The Continuous Sealer was manufactured by:

Audion Elektro BV	
Hogeweyselaan 235	
1382 JL Weesp	
The Netherlands	
Telephone:	+ 31 (0)294 491717
Fax:	+ 31 (0)294 491755
Email:	holland@audion.nl
Web:	www.audion.com

1.2 Machine type plate

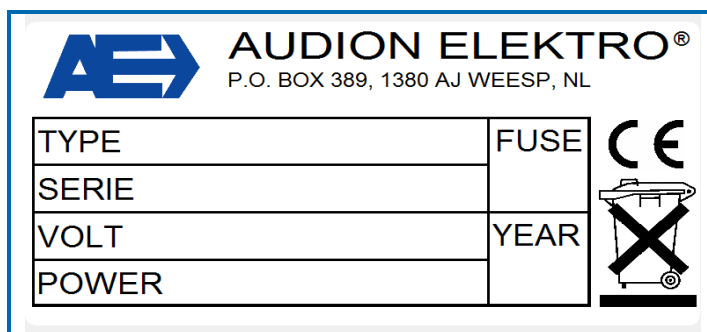

Figure 1-1: Machine type plate of the Continuous Sealer

The sealer has an EC mark. This means that the sealer meets the fundamental health and safety requirements of the European Communities.

1.3 Warranty conditions and liability

Subject to the restrictions stated below, we provide a 12-month warranty regarding the products delivered by us. This warranty is limited to manufacturing defects and therefore does not cover any malfunctions caused by any form of wear, or any part of the delivered product that is subject to wear.

- The warranty we provide for parts or accessories purchased from third parties is limited to the warranty the third-party provides to us.
- If the other party, and/or any third parties engaged by them, makes unskilled use of the product delivered, the warranty becomes void.
- The warranty is also void if the other party and/or any third parties engaged by them carries out work and/or modifications on the delivered product.
- Any parts we replace in order to meet our warranty obligations become our property.
- Should the other party not meet obligations resulting from the agreement entered into between the parties in whole or in part or in a timely manner, we are not obliged to provide warranty for as long as that situation continues.

We exclude all liability to the extent that the liability is not regulated by law. Our liability will never exceed the total amount of the order in question.

Subject to the generally applicable legal rules of public order and good faith, we are not obliged to pay compensation to the other party or any third party for damages of any nature whatsoever, incurred directly or indirectly, including trading loss, damage to movable or immovable property or persons.

In any case, we are not liable for any damage resulting from or caused by using the delivered product or its unsuitability for the purpose for which the other party purchased it.

2 Safety

2.1 Symbols used in this manual

The following symbols are used in this user manual:



A tip on how a task can be carried out more efficiently.



Instructions for carrying out a task in the correct manner.



Danger of injury to the user or damage to the sealer if the instructions are not observed.

2.2 User



The sealer should only be operated by authorised personnel.



Improper use of the sealer may lead to serious personal injury and considerable material damage.



Keep bystanders at a distance. Do NOT allow unauthorised personnel to operate the sealer.

2.2.1 Operating personnel

The company using the machine has organized a training to inform its operating personnel of the potential risks of unskilled behaviour while carrying out their tasks.



Installation, maintenance and repair require specialised knowledge, which is why these tasks should only be performed by maintenance personnel.



Observe the safety instructions in this user manual. Failure to observe the safety instructions may cause unacceptable risks.

The operating personnel must be familiar with all chapters of this user manual with the exception of 'Installation' and 'Maintenance'. Always observe the following safety instructions before using the sealer or carrying out any maintenance work.

2.2.2 Maintenance personnel

This personnel's professional training, knowledge and experience, and knowledge of the manufacturer's terms enable them to carry out the assigned work and immediately recognize any risks that may arise.



Observe the safety instructions in this user manual. Failure to observe the safety instructions may cause unacceptable risks.

Maintenance personnel must be familiar with all chapters of this user manual. Always observe the following safety instructions before using the sealer or carrying out any maintenance work on it.

2.3 Safety instructions

The sealer meets the fundamental health and safety requirements of the European Community. This means that the sealer can be operated and maintained safely if all safety instructions are carefully observed. However, improper or careless use can create dangerous situations.



Observe the safety instructions in this user manual. Always remain alert to dangerous situations and avoid any improper or careless use.

2.3.1 General safety instructions

Observe the following general safety instructions:

- Tie back long hair.
- Do not wear loose clothing or jewellery.



- Always wear the personal protective equipment (PPE) prescribed by the company, such as safety shoes, gloves, and goggles.



Use the PPE required on the shop floor, such as safety shoes, gloves and goggles and/or hearing protection, in particular when carrying out maintenance work.

- Check the operation of the sealer every day.
- Keep your hands away from dangerous parts of the sealer.
- Always leave protective covers in place during production.
- Never bypass or deactivate any safety provisions.
- The sealer should never be operated or maintained by people who are under the influence of alcohol, medication and/or drugs.
- Only use sealable material that is suitable for the sealer.
- The user is obliged to observe the normally applicable hygienic measures
- If you are in doubt about the correct functioning of the machine, switch it off and consult the maintenance personnel.
- Both the user and the sealer must be supervised while the sealer is in use.

- Do not switch the sealer back on until the malfunction has been repaired.
- Should any liquid or foreign object enter the machine, switch off the sealer and immediately remove the plug from the wallsocket and have the sealer checked by maintenance personnel before using it again.
- Should an unusual event occur, such as the development of smoke, remove the plug from the socket immediately and have the sealer checked by maintenance personnel before using it again.
- Remove the plug from the socket before carrying out any maintenance work.
- Never open the sealer's housing while it is connected to the mains power.
- Do not use any water, abrasive cleaning agents, chemical solvents or other liquids when cleaning the sealer.

2.3.2 What to do in case of fire



NEVER use water to extinguish a fire. This may result in life-threatening situations because the sealer may be live.

Should the sealer catch fire, never use water to extinguish the fire. Because the machine is live, this may result in life-threatening situations. During use, you are obliged to have a fire extinguisher within reach of the machine. The following types of fire extinguishers are suitable to extinguish fires occurring to this machine:

- Powder extinguisher.
- Foam extinguisher.

2.3.3 Use for special applications



If the machine is used in a specialised environment, the company using the machine is responsible for making sure any specific instructions that apply are observed.

- If the machine is used in a medically sterile environment or cleanroom, the company using the machine is responsible for making sure any specific instructions that apply there are observed.
- If the machine is used for the packaging of medical instruments, the company using the machine is responsible for making sure any specific instructions that apply are observed.
- If the machine is used for the packaging of food, the company using the machine is responsible for making sure any specific instructions that apply are observed.

2.4 Safety provisions

The sealer has the following safety provisions:

1. Safety covers.
 - Electrical and mechanical parts in the housing are protected.
2. Metal parts are earthed.
 - No dangerous voltage can develop between (external) metal parts and the earth.
3. Fuse in 230 V circuit.
 - If the voltage gets too high, the fuse will blow, cutting off the power supply.
4. Emergency stop button
 - In case of a hazard, this will immediately and completely switch off the sealer.

2.5 Safety symbols

The following safety symbols are applied to the Continuous Sealer:

- **'Hot surfaces'**.

On the front of the Continuous Sealer on the cover. It may get hot because of the heating elements.



3 Installation

3.1 Unpacking the sealer

Check the following when unpacking the sealer:

1. **Are** all parts and accessories present?
 - Sealer
 - User manual



The sealer is packaged in environmentally friendly material that can be disposed of as ordinary household waste.



Keep the crate and the packaging material so the sealer can be safely transported, should such be necessary.

3.2 Placing the sealer

1. **Place** the sealer in the desired location.
2. **Lock** the castors by depressing the brakes.

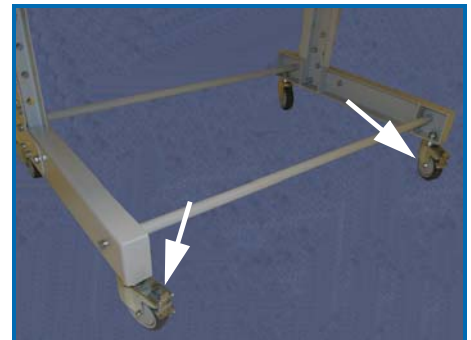

3.3 Connecting the sealer

1. Check whether the main switch is in the '0' position.



2. Put the plug in the socket.



3.4 Adjusting the sealer

You can make the following adjustments:

- Height of sealing unit in relation to the conveyor belt; to adjust the length of the bags.
- Horizontal distance between conveyor belt and sealing unit; to adjust the position of the bags on the conveyor belt.
- Height of conveyor belt in relation to the floor; to adjust the working height.

3.4.1 Adjusting the height of the sealing unit

The height of the sealing unit in relation to the conveyor belt is adjusted as follows:

1. **Set** the height of the sealing unit by rotating the crank.



The top of the bag to be sealed should be able to move freely along the top of the infeed guide.



3.4.2 Adjusting the horizontal position of the conveyor belt

The horizontal distance of the conveyor belt in relation to the sealing unit is adjusted as follows:

1. **Loosen** the four locking bolts a number of turns.
2. **Adjust** the position of the conveyor belt in relation to the sealing unit by shifting the conveyor belt.



The position of the conveyor belt is to be adjusted in such a way that the bag to be sealed is in the centre of the conveyor belt as far as possible.

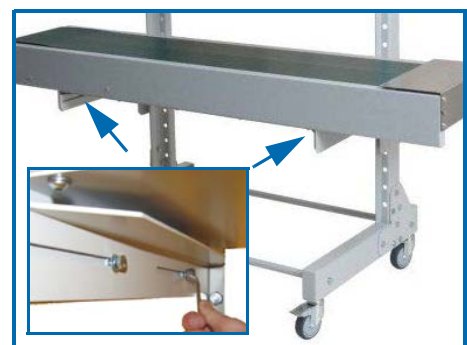

3. **Tighten** the locking bolts again.

3.4.3 Adjusting the height of the conveyor belt

The height of the conveyor belt is adjusted as follows:

1. **Loosen** the 2 mounting nuts at the back of the conveyor-belt brackets.
2. **Take** the conveyor belt from the frame.



Always make sure two people lift the conveyor belt from the frame together.



3. **Position** the conveyor belt on the frame at the desired height.



The height of the conveyor belt is to match the infeed and outfeed belts.



Always make sure two people position the conveyor belt on the frame together.

4. **Tighten** the mounting nuts again.

4 Description of the sealer

4.1 Function

The Continuous Sealer is a band sealer for the packaging of a wide variety of products in larger quantities. The products are packaged in ready-to-use bags and subsequently sealed. The sealer is suitable for the sealing of ready-to-use bags made of polyethylene (PE), polypropylene (PP), thin PVC, and various laminates with a thickness of between 20 μ m and 150 μ m.



Do not use the Continuous Sealer for any other applications.

The sealer is not suitable for the following applications:

- Use in a clean room environment.
- Use in a medical, sterile environment.
- Use in an explosive environment.
- Use of toxic, asphyxiant or irritating gases.
- Use of the machine in a dusty environment.

4.2 Overview of the sealer



Figure 4-1: Overview of the sealer

1. Housing
2. Control panel
3. Conveyor belt
4. Setting of distance and height of the conveyor belt in relation to the sealing unit
5. Frame with castors.

The sealer comprises a frame with castors onto which a conveyor belt and housing are mounted. The housing comprises the electrical and drive components; the operating panel is mounted on top of the housing. During maintenance work, the housing can be tilted to make the interior easily accessible.

The conveyor belt will transport the bags to be sealed along the heating blocks, the press rollers, the cooling plates, and the after-press rollers that are positioned inside the housing.

The height of the conveyor belt is adjustable to make it seamlessly match the infeed and outfeed belts. Also, the vertical distance between the conveyor belt and the housing is adjustable so that bags of different heights can be sealed, and the horizontal position of the conveyor belt in relation to the sealing unit is adjustable so that the bags are in the centre of the conveyor belt as far as possible.

4.3 Control panel

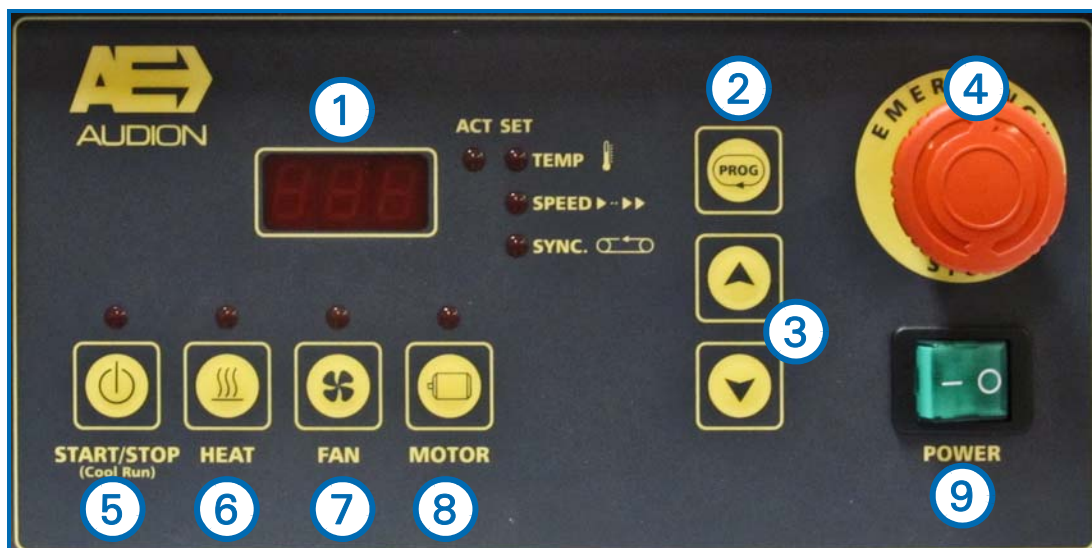

Figure 4-2: Control panel

- | | |
|--------------------------|--|
| 1. Display | Indicates the actual sealing temperature, speed or a malfunction notification. While adjusting the values, the set value will be shown. |
| 2. Prog | Press to change the settings menu of the sealer. An led next to the button will indicate which setting can be adjusted:
Temp, the sealing temperature.
Speed, the sealing speed.
Sync., synchronising the sealing speed and the speed of the conveyor belt. |
| 3. Up/down | Press to increase or reduce a setting. |
| 4. Emergency stop button | In case of a hazard, this will immediately and completely switch off the sealer. |
| 5. Start/stop | Press to start or stop the sealer. An led above the button indicates whether the sealer is switched on or off. When the actual sealing temperature upon switching off is over 80°C, the sealer will first switch to Coolrun mode. |
| 6. Heat | Press to switch the heating on or off. An led above the button indicates whether the function is switched on or off. |
| 7. Fan | Press to switch the blower on or off. An led above the button indicates whether the function is switched on or off. |
| 8. Motor | Press to switch the motor on or off. An led above the button indicates whether the function is switched on or off. |
| 9. Main switch | Press to switch the sealer on or off. |

Coolrun mode

The coolrun mode prevents burning of the PTFE belts. After the machine has been stopped, the heater is switched off; however, the blower and the motor will continue to run. When the sealing temperature has dropped to below 80°C, the sealer is switched to stand-by mode and the blower and the motor will also be switched off.

5 Operation

5.1 Preparing the sealer for production

5.1.1 Switching on the sealer

Switch on the sealer as follows:

1. **Set** the MAIN SWITCH to '1'.



If necessary, put the plug in the socket.

2. If necessary, **turn** the EMERGENCY STOP BUTTON clockwise to reset it.

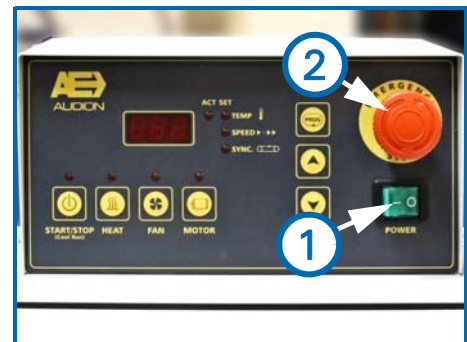

5.1.2 Setting the sealing temperature and speed

The sealing temperature and speed are set as follows:

1. **Press** the PROG button until the TEMP led is on.
2. **Press** the ARROW keys to increase or reduce the sealing temperature.



The guideline value for the sealing temperature is 100°C.

3. **Press** the PROG button until the SPEED led is on.
4. **Press** the ARROW keys to increase or reduce the speed of the conveyor belt.



The guideline value for the speed is 50.

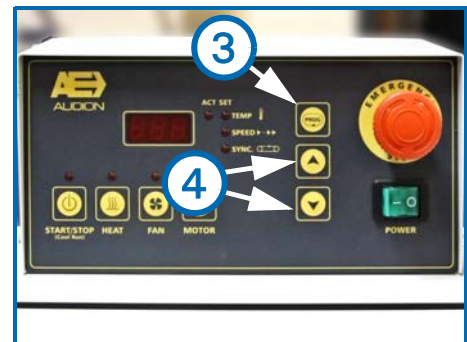
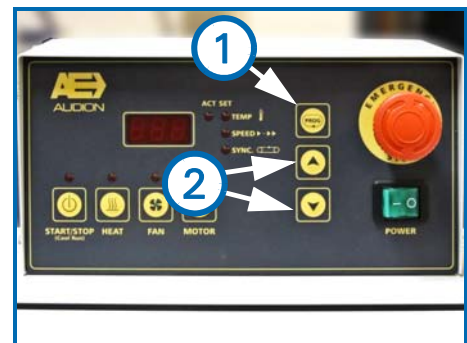

5. Press the PROG button until the actual sealing temperature is once again shown in the display.



The TEMP led will blink if the set temperature deviates more than 5°C from the actual sealing temperature.



Make a number of trial seals and, if necessary, readjust the sealing temperature and speed.



5.1.3 Switching on the heating, the cooling and the blower

Switch on the heating, the cooling and the blower as follows:

1. Press the HEAT button.
2. Press the MOTOR button.



The heating and transport motor must always be switched on before use.



3. If necessary, press the FAN button.



If a paper or aluminium-laminate film is used, the FAN (blower) does not have to be switched on. Make sure to switch on the blower, however, when using PE film types.



5.1.4 Starting the sealer

Start the sealer as follows:

1. **Press** the START/STOP button.
2. **Wait** until the TEMP led is no longer blinking.



The sealer has now reached the set temperature and is ready for sealing.

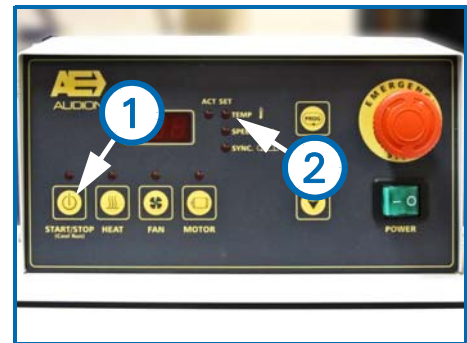

5.2 Sealing

Bags are sealed as follows:

1. **Position** the bags on the conveyor belt and guide the bag into the infeed guide.



Make a number of trial seals first to make sure the settings are correct. If necessary, readjust the sealing temperature and speed.



5.3 Stopping the sealer (STANDBY mode)

After use, stop the sealer as follows to put it in STANDBY mode:

1. Press the START/STOP button.



The sealer will now switch to STANDBY mode; the display will show "---".

When the sealing temperature is over 80°C, the sealer will first switch to COOLRUN mode. The heating is switched off and the blower and the motor will continue to run until the sealing temperature has dropped to below 80°C. The display will alternately show "c-r" and the "actual sealing temperature".

After that, the sealer is switched to STANDBY mode.



If the sealer is not going to be used for a longer period of time, it is better to switch it off completely by means of the MAIN SWITCH.



5.4 Emergency stop

In case of an emergency, switch off the sealer completely as follows:

1. Press the EMERGENCY STOP BUTTON.



In case of emergency situations, always make use of the EMERGENCY STOP BUTTON immediately. Do not use the EMERGENCY STOP BUTTON to switch off the sealer in normal circumstances.



5.4.1 Restarting after an emergency stop

After an emergency stop, restart the sealer as follows:



Make sure the cause of the fault/malfunction has been removed before restarting the sealer.

1. Turn the EMERGENCY STOP BUTTON clockwise to reset it.
2. Press the START/STOP button.



The sealer is now ready for use again. Possibly the Temp led will be blinking; in that case, the sealer has to heat up again first.

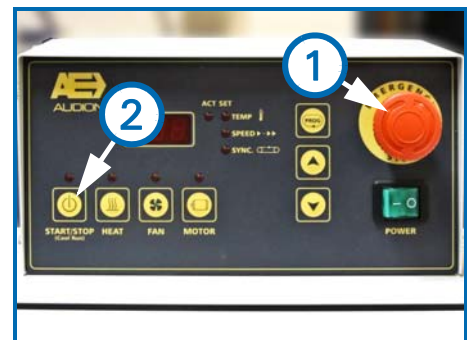

5.5 Switching off the sealer completely

Switch off the sealer completely as follows:

1. Set the MAIN SWITCH to '0'.



6 Troubleshooting



Troubleshooting may only be performed by authorised maintenance personnel.



In the event of a malfunction, always remove the plug from the socket before attempting to solve the problem.



If the problem cannot be solved using the troubleshooting table below, please contact your dealer or Audion.

Problem	Cause	Solution
The sealer does not respond in any way.	The main switch is set to '0'.	Switch on the sealer.
	The plug is not, or not properly, connected to the socket.	Put the plug properly in the socket.
	The power supply is out of order.	Check the power supply.
	The emergency stop button has been pressed.	Reset the emergency stop button.
	Internal malfunction.	Contact your dealer or Audion.
The seal is not neat.	The temperature has not been set correctly.	Readjust the temperature.
	The speed has not been set correctly.	Readjust the speed.
	The heating blocks and/or the PTFE belts are dirty.	Clean the heating blocks and/or the PTFE belts.
	The seal is not cooled properly.	Switch on the cooling.
	The heating block, the cooling plate and/or the press rollers are still in the uppermost position.	Put the heating block, the cooling plate and/or the press rollers in the lowermost position.
	The PTFE belts are worn.	Replace the PTFE belts.

Problem	Cause	Solution
The cooling is not working.	The blower is not on.	Switch on the blower.
	The cooling plates are set too high.	Set the cooling plates correctly.
	Internal malfunction.	Contact your dealer or Audion.
Error code E1	Frequency setting 50 Hz or 60 Hz (PCB jumpers) is incorrect.	Check the frequency of the grid and set the PCB jumpers correctly.
Error code E2	Loose wire in the temperature sensor (PT100).	Check the connection of the wiring of the temperature sensor (PT100).
Error code E3	Short circuit in the temperature sensor (PT100).	Replace the temperature sensor (PT100).
The conveyor belt is not running.	The speed is set to '0'.	Readjust the speed to a higher value.
	Internal malfunction.	Contact your dealer or Audion.

7 Maintenance



Maintenance should only be performed by authorised maintenance personnel.



Always remove the plug from the socket before carrying out any maintenance work.



Do not use any water, abrasive cleaning agents, chemical solvents or other liquids when cleaning the machine.



The maintenance schedule is based on normal use. The frequency of maintenance must be increased if the machine is used intensively or under extreme conditions.



Always keep a log of all maintenance work. An example is given in Appendix 4 - 'Log'.

7.1 Maintenance schedule

7.1.1 Daily maintenance



Daily maintenance should be carried out by the operating personnel (see foreword).

Part	Work
PTFE belts	Make sure the PTFE belts are clean. If necessary, clean with a damp cloth.
Heating blocks	Make sure the heating blocks are clean. If necessary, clean with a damp cloth.

7.1.2 Weekly maintenance



Weekly maintenance should only be performed by authorised maintenance personnel (see the preface).

Part	Work
Drive	Check the rotating parts and chains. If necessary, lubricate.
V belts	Check the V belts on cracks and tension.
Conveyor belt	Check the conveyor belt on cracks and tension.
Cleaning	Clean the sealer with a damp cloth and mild soap (for example, all-purpose cleaner).

7.1.3 Annual maintenance



Annual maintenance should only be performed by authorised maintenance personnel (see the preface).

Part	Work
Earth system	Check the earth according to NEN 3140 or EN 50110-1.

7.2 Switching off the sealer and opening the protective cover

Open the protective cover as follows:

1. **Set** the main switch to '0'.
2. **Remove** the plug from the socket.



Never carry out maintenance on the Continuous Sealer while it is live.

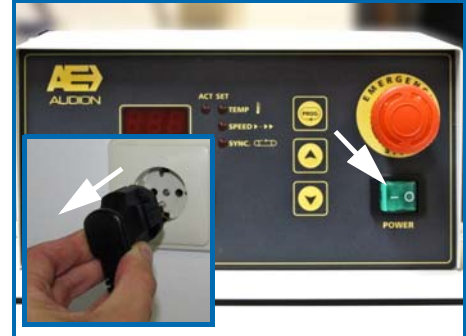

3. **Loosen** the two locking handles at the sides a few turns.
4. **Tilt** the housing so that the sealing slit is at the front.
5. **Tighten** the two locking handles again.

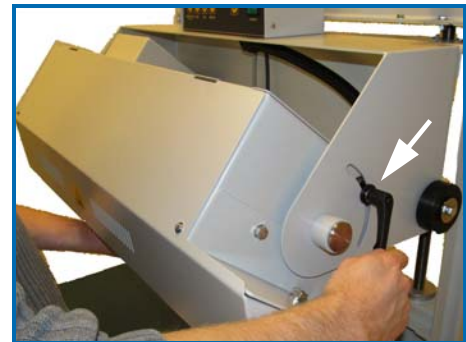

6. **Loosen** the two bolts near the infeed slit.



7. **Open up** the protective cover.



Warning! The heating blocks can still be hot, even if the sealer has been switched off for a while.

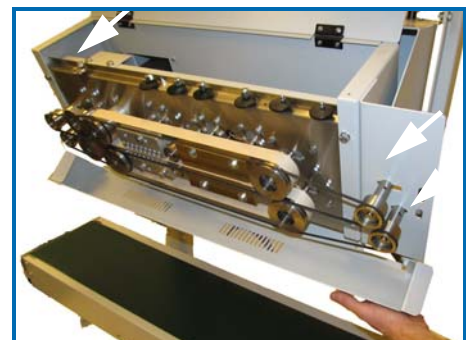

7.3 Replacing the PTFE belts



Warning! *The heating blocks can still be hot, even if the sealer has been switched off for a while.*

Replace the PTFE belts as follows:

1. Put the cooling plate, the after-press roller and the heating block in the uppermost position.



Pull the lifting pin up and turn the lifting plate in such a way that it appears over the edge of the protective cover.

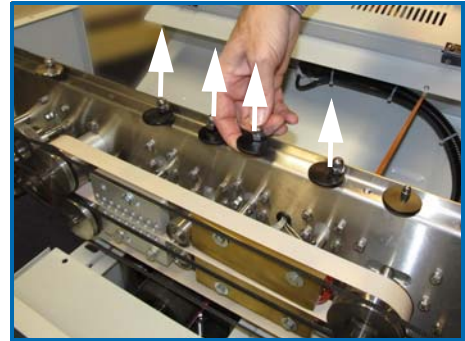

2. Push the two tension rollers inward until they are locked.



While pushing the tension roller inward, the locking pin will fall into a recess, preventing the tension roller from springing back.

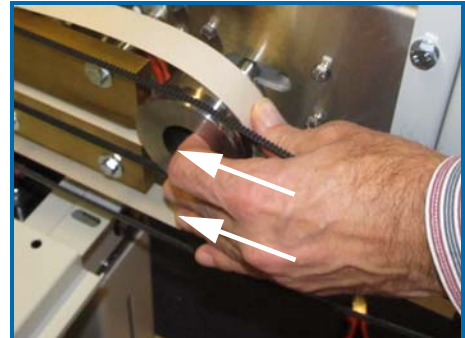

3. Remove the V belts by pushing these from the pulleys using a rotating movement.



4. Remove the old PTFE belts and place new ones.



Make sure no folds occur in the PTFE belts. These may cause breaking during use.

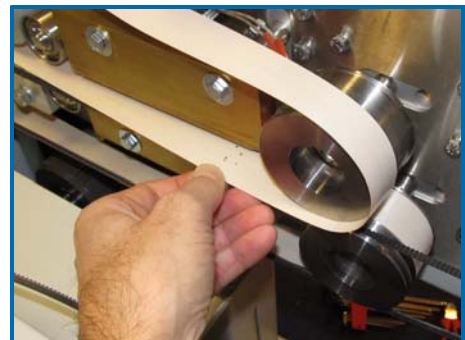

5. Pull the locking pins of the tension rollers upward and allow the tension rollers to gently spring back.



Make sure the PTFE belts run smoothly across the rollers.

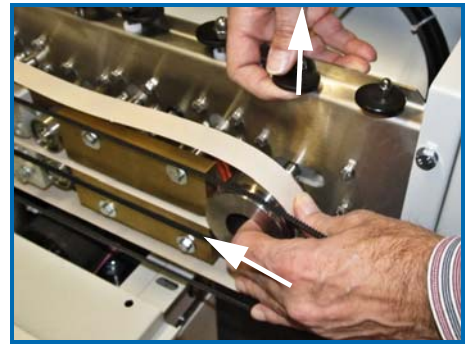

6. Place the V belts back across the pullies.



Make sure the V belts run smoothly across the rollers with the serrated edge on the outside.



7. Put the cooling plates, the after-press roller and the heating block back in the lowermost position.



Pull the lifting pin up and turn the lifting plate in such a way as to allow the lifting pin to go down all the way.

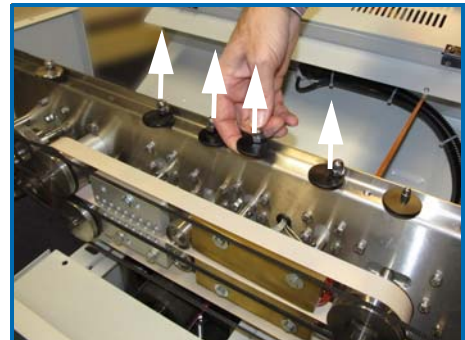

7.4 Replacing the V belts

Replace the V belts as follows:

1. **Remove** the V belts by pushing these from the pullies.
2. **Place** the V belts back across the pullies.



Make sure the V belts run smoothly across the rollers with the serrated edge on the outside.



7.5 Adjusting the V belts

The V belts are adjusted as follows:

1. **Loosen** the nut at the back of the shaft one turn.



Do not loosen the nut completely, otherwise the tension roller will not remain suspended.



2. **Slide** the tension roller to the left/right to relieve/tension the V belt.



The long belts should be able to move up and down approximately 1 cm in the centre; the short ones approximately 0.5 cm.

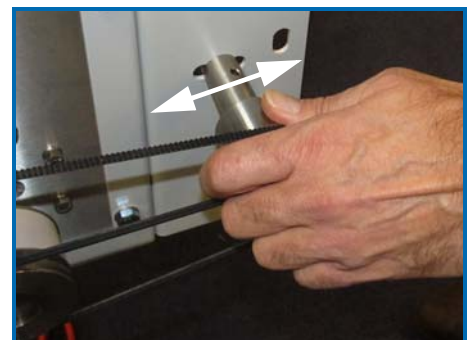

3. **Tighten** the bolt at the back of the shaft again.



If the V belt has to be tensioned frequently, it is worn and should be replaced.

7.6 Replacing the heating elements

Replace the heating elements as follows:

1. **Loosen** the clamping screws in the connecting block.
2. **Pull** the wires from the connecting block.
3. **Cut** through the cable binders.



4. **Put** the heating block in the uppermost position.



Pull the lifting pin up and turn the lifting plate in such a way that it appears over the edge of the protective cover.

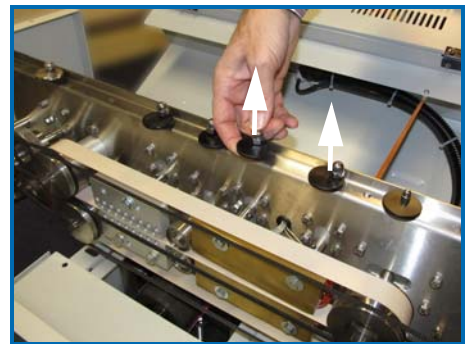

5. **Loosen** the mounting bolts.
6. **Take** the heating block from the machine.

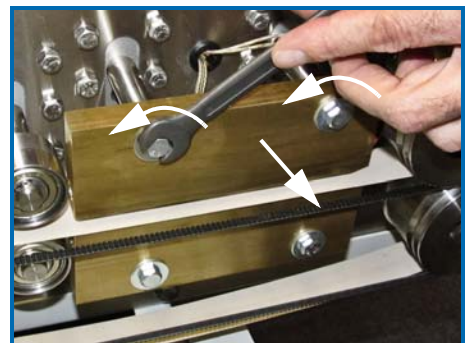

7. **Loosen** the Allen bolt at the back of the heating block.
8. **Take** the heating element from the heating block.
9. **Place** a new heating element.
10. Carefully **tighten** the Allen bolt at the back of the heating block.

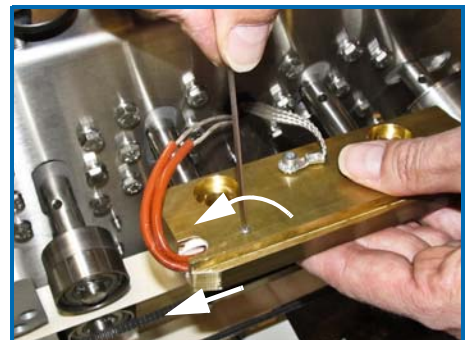

Do not tighten the Allen bolt too much, or the heating element may get damaged.

11. Push the connecting wires through the opening.
12. Place back the heating blocks.
13. Tighten the mounting bolts again.



Note that the upper heating block should still be able to move up and down somewhat after tightening of the mounting bolts.



14. Push the connecting wires back into the connecting block.



Take care to connect the wires in the correct position.



15. Tighten the screws in the connecting block again.
16. Fix the connecting wires again, using cable binders.
17. Put the heating block back in the lowermost position.



Pull the lifting pin up and turn the lifting plate in such a way as to allow the lifting pin to go down all the way.



7.7 Adjusting the pressing force of the heating blocks

The heating blocks are adjusted as follows:

1. Turn the setting nut to adjust the pressing force.



Try to keep the pressing force down as far as possible so as to minimise wear and tear on the PTFE belts. If necessary, the pressure may be increased for materials that are difficult to seal. Always check whether the bag is not blocked or stuck during sealing.

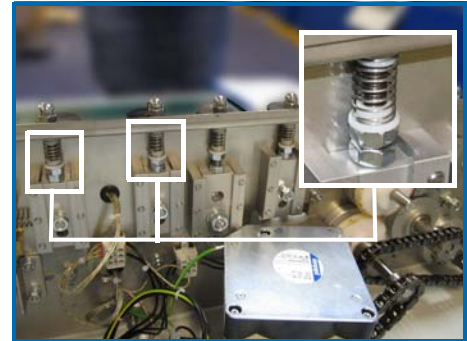

Turn to the left to increase the pressing force and to the right to reduce it.



Note that the adjustment depends on the position (horizontal or vertical) of the housing.



Adjust both nuts equally.

7.8 Adjusting the pressing force of the press rollers

The press rollers are adjusted as follows:

1. Turn the setting nuts to adjust the pressing force.



Try to keep the pressing force down as far as possible so as to minimise wear and tear on the PTFE belts. If necessary, the pressure may be increased for materials that are difficult to seal. Always check whether the bag is not blocked or stuck during sealing.

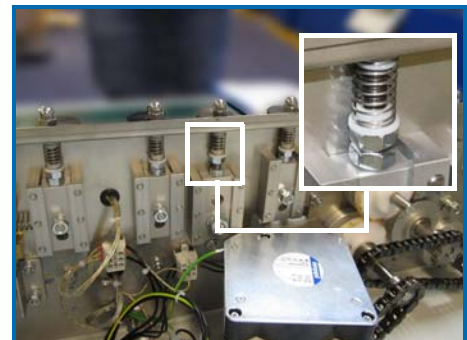

Turn to the left to increase the pressing force and to the right to reduce it.



Note that the adjustment depends on the position (horizontal or vertical) of the housing.

7.9 Adjusting the pressing force of the cooling plates

The cooling plates are adjusted as follows:

1. Turn the setting nut to adjust the pressing force.



Try to keep the pressing force down as far as possible so as to minimise wear and tear on the PTFE belts. If necessary, the pressure may be increased for materials that are difficult to seal. Always check whether the bag is not blocked or stuck during sealing.



Turn to the left to increase the pressing force and to the right to reduce it.



Note that the adjustment depends on the position (horizontal or vertical) of the housing.

7.10 Adjusting the pressing force of the after-press rollers

The cooling plates are adjusted as follows:

1. Turn the setting nut to adjust the pressing force.



Try to keep the pressing force down as far as possible so as to minimise wear and tear on the PTFE belts. If necessary, the pressure may be increased for materials that are difficult to seal. Always check whether the bag is not blocked or stuck during sealing.



Turn to the left to increase the pressing force and to the right to reduce it.



Note that the adjustment depends on the position (horizontal or vertical) of the housing.

7.11 Adjusting the tension of the conveyor belt

The conveyor belt is adjusted as follows:

1. **Loosen** the two locking nuts at the bottom of the conveyor belt a few turns.



2. **Turn** the tightening bolts to adjust the pressing force.



Turn to the right to increase the tension in the conveyor belt; to the left to reduce it.



Make sure the tension is equal on both sides and that the conveyor belt is not drawn askew.

3. **Tighten** the two locking nuts again.

8 Disposing of the machine



Correct disposal of the machines and equipment helps protect the environment and public health.

8.1 Directive 2002/96/EC

According to the European Directive 2002/96/EC regarding waste electrical and electronic equipment (WEEE), the adjacent icon indicates that the machine or the piece of equipment to which it has been applied, as it is disposed of, is to be collected separately from the other waste and may not be discarded together with residual waste.

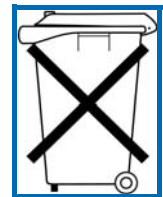

8.2 Correct disposal for reuse

The machine or piece of equipment is to be presented to a disposal station or, in case of replacement, to the supplier of the replacement machine or piece of equipment.

For more information, please contact the local agency responsible for the collection of waste and the like, or the municipal waste depot.



The owner of the machine or piece of equipment is responsible for the correct disposal of the machine.

Appendix 1

Technical information

A1.1 Dimensional drawing

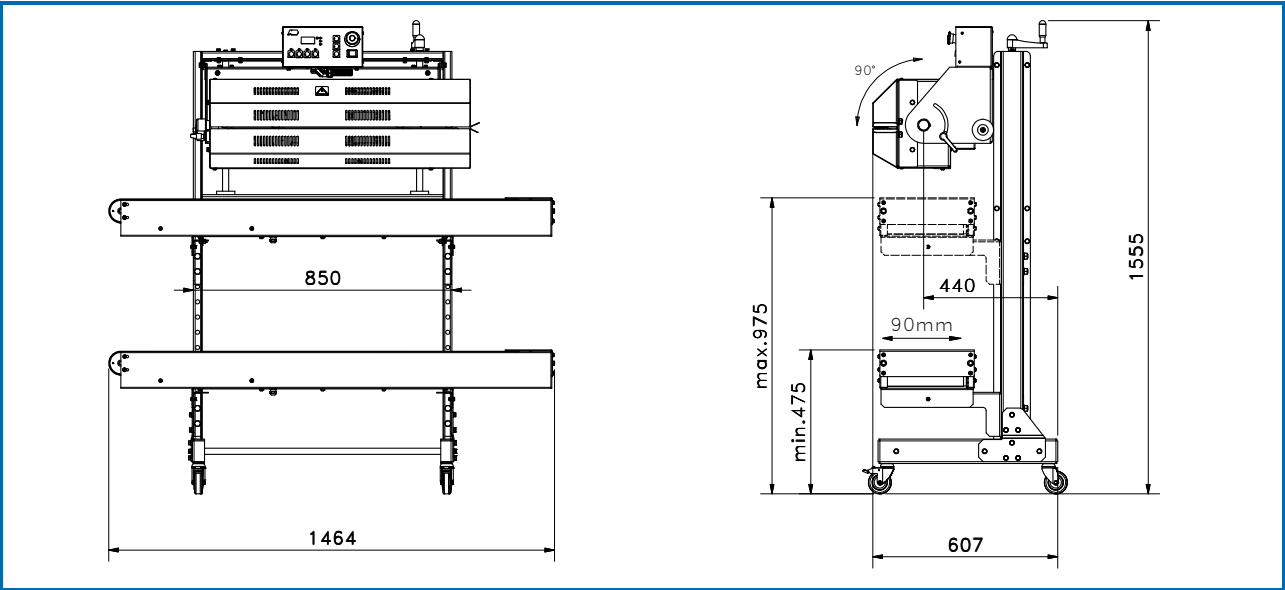

Figure 8-1: Dimensional drawing

A1.2 Technical information

General	
Dimensions	See the dimensional drawing
Weight	93 kg
Ambient temperature	+ 5 °C - + 40 °C
Humidity	30% - 95% rel. without condensation
Seal length	unlimited
Seal width	10 mm
Sealing speed	Max. 10 metres per minute
IP value	IP20
Electricity	
Voltage	230 V - 16 A
Frequency	50-60 Hz
Earthing	earthed
Power	1100 W
Deviation from mains power system	< 10%
Fuse	4 AT
Length of power cord	± 1.8 m
Film	
Min. film thickness	20 μ m
Max. film thickness	150 μ m
Max. film insert	40 mm
Max. film width	unlimited
Bag dimensions	
Max. weight (on conveyor belt)	10 kg
Max. bag length	420 mm
Max. volume	unlimited
Emission	
Noise	< 70 dB(A)
hand/arm vibration	< 2.5 m/s ²

Appendix 2

Electrical Diagram



Maintenance to the electrical installation may only be performed by authorised maintenance personnel.



Always remove the plug from the socket before carrying out maintenance work on the electrical installation.

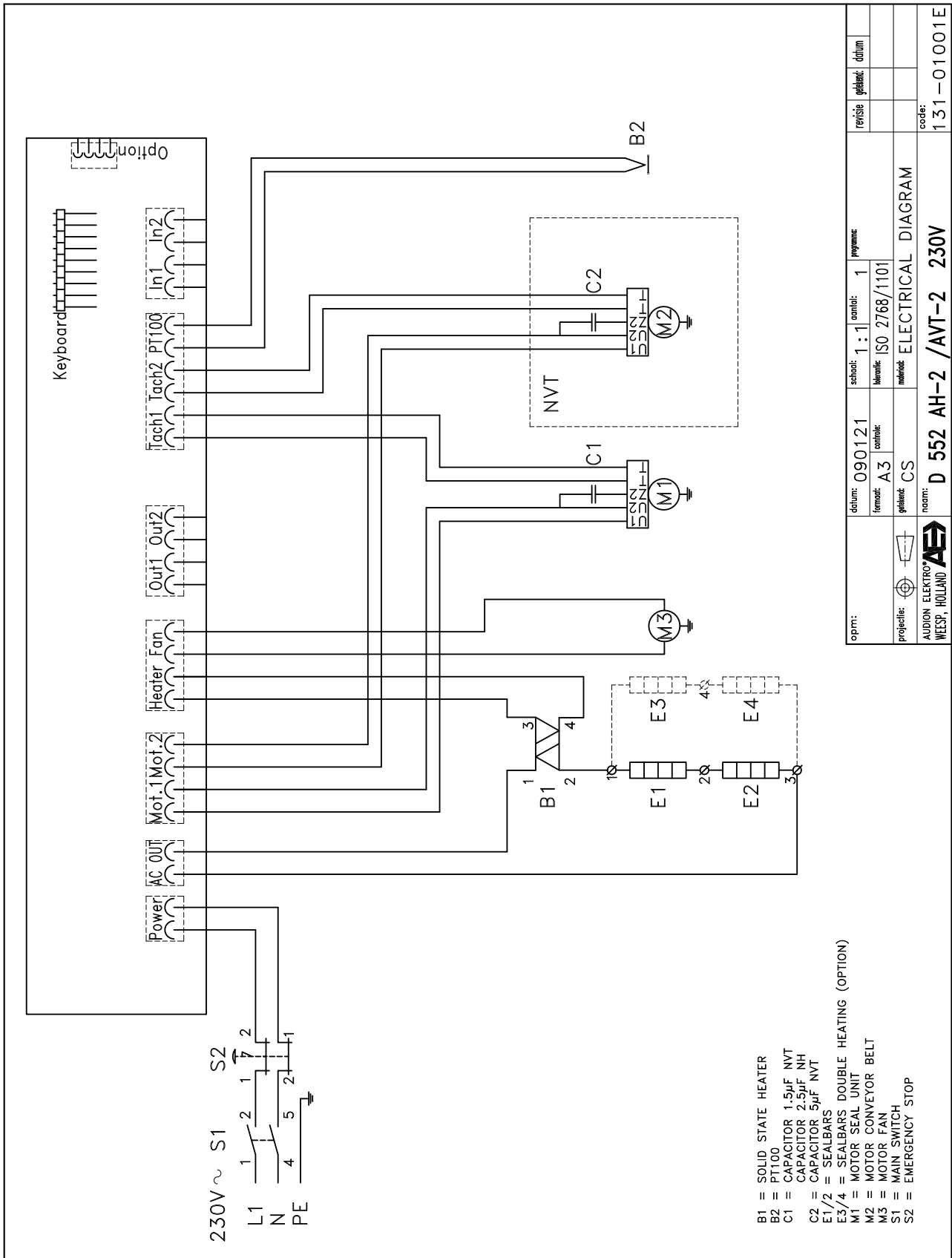

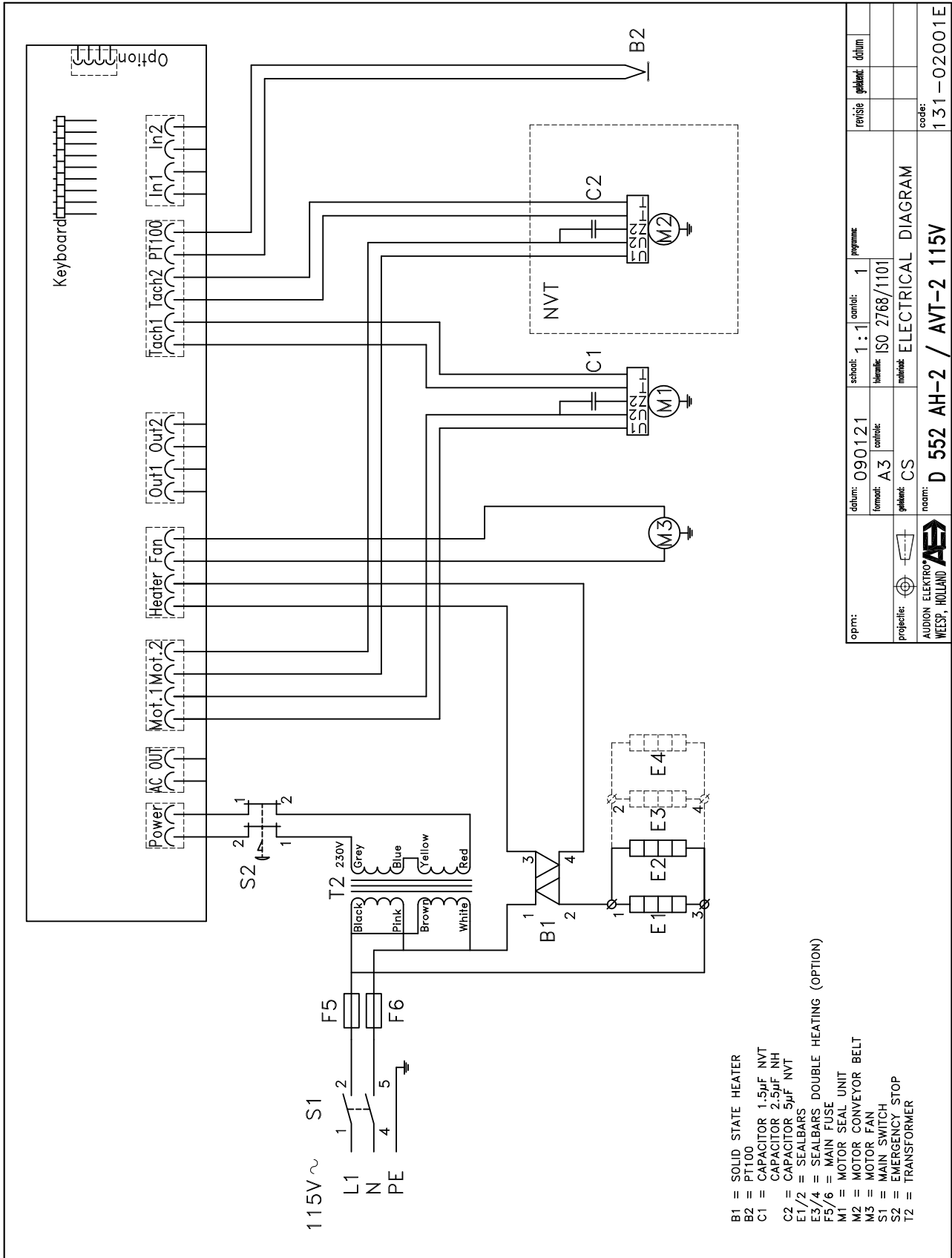

oprnr:	datum: 090121	schndf: 1 : 1	contfcl: 1	prgramm:	revisie	gkdati	dtlhm
projectie:	formaat: A3	contfcl:	norm: ISO 2768/1101				
	gkdati: CS	method:	ELECTRICAL DIAGRAM				
	norm: D 552 AH-2 / AVT-2 115V						code: 131-02001E

Appendix 3

Spare parts



Only use original Audion parts for repairs and maintenance.



Repairs and maintenance may only be performed by authorised maintenance personnel.



Always keep a set of recommended consumables in stock so that a defective part can be replaced quickly and the production process resumed without delay.

A3.1 Consumables

Part	Qty per machine	Article number
V belt large	2	685216-14
V belt small	2	685205-11
PTFE belt width 25 mm	2	685206-20
Heating element (PT100)	2	685209-11
Set of consumables 2x V belt large 2x V belt small 4x PTFE belt width 25 mm 2x heating element (PT100)		130-1203

A3.2 Exploded views

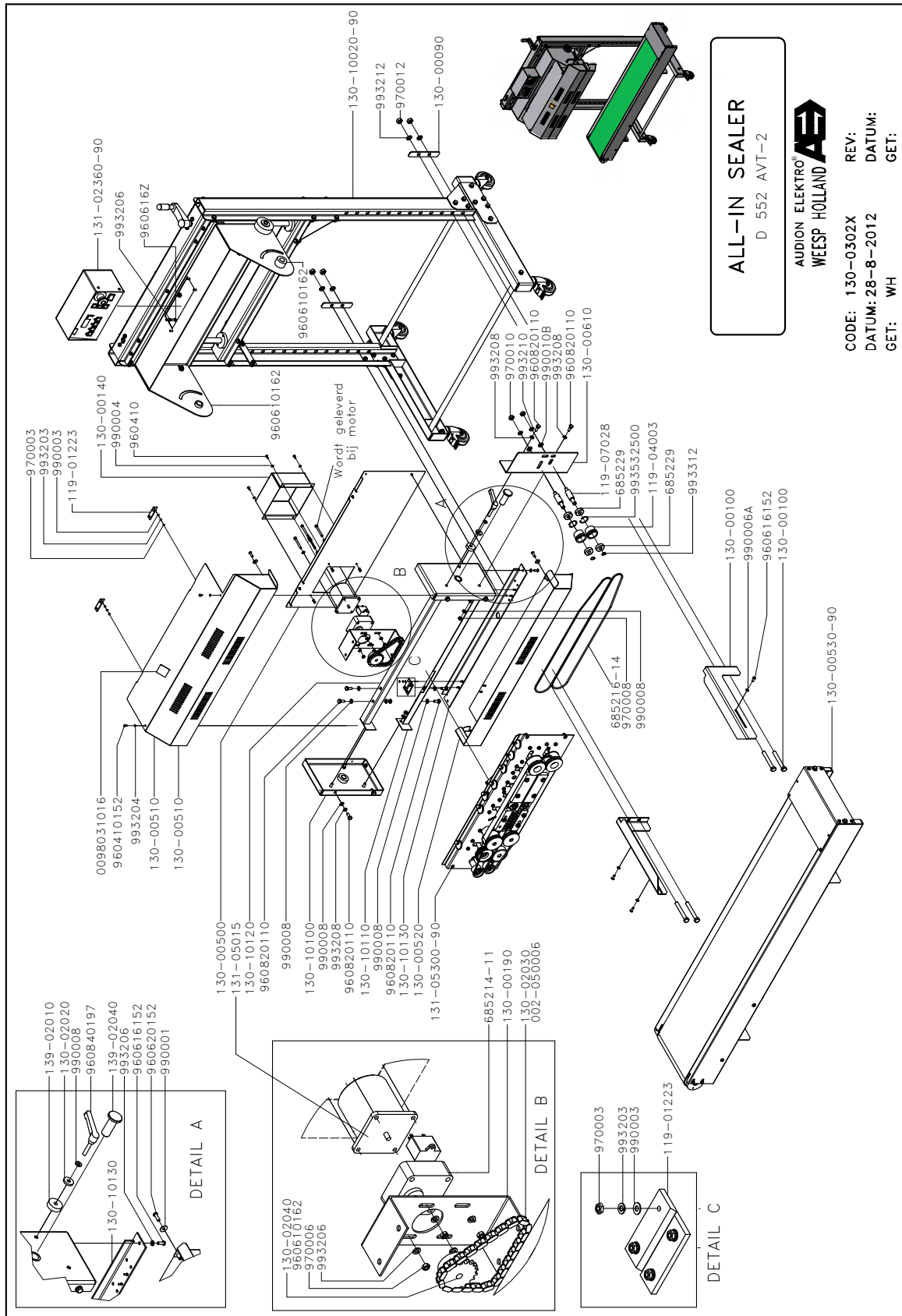

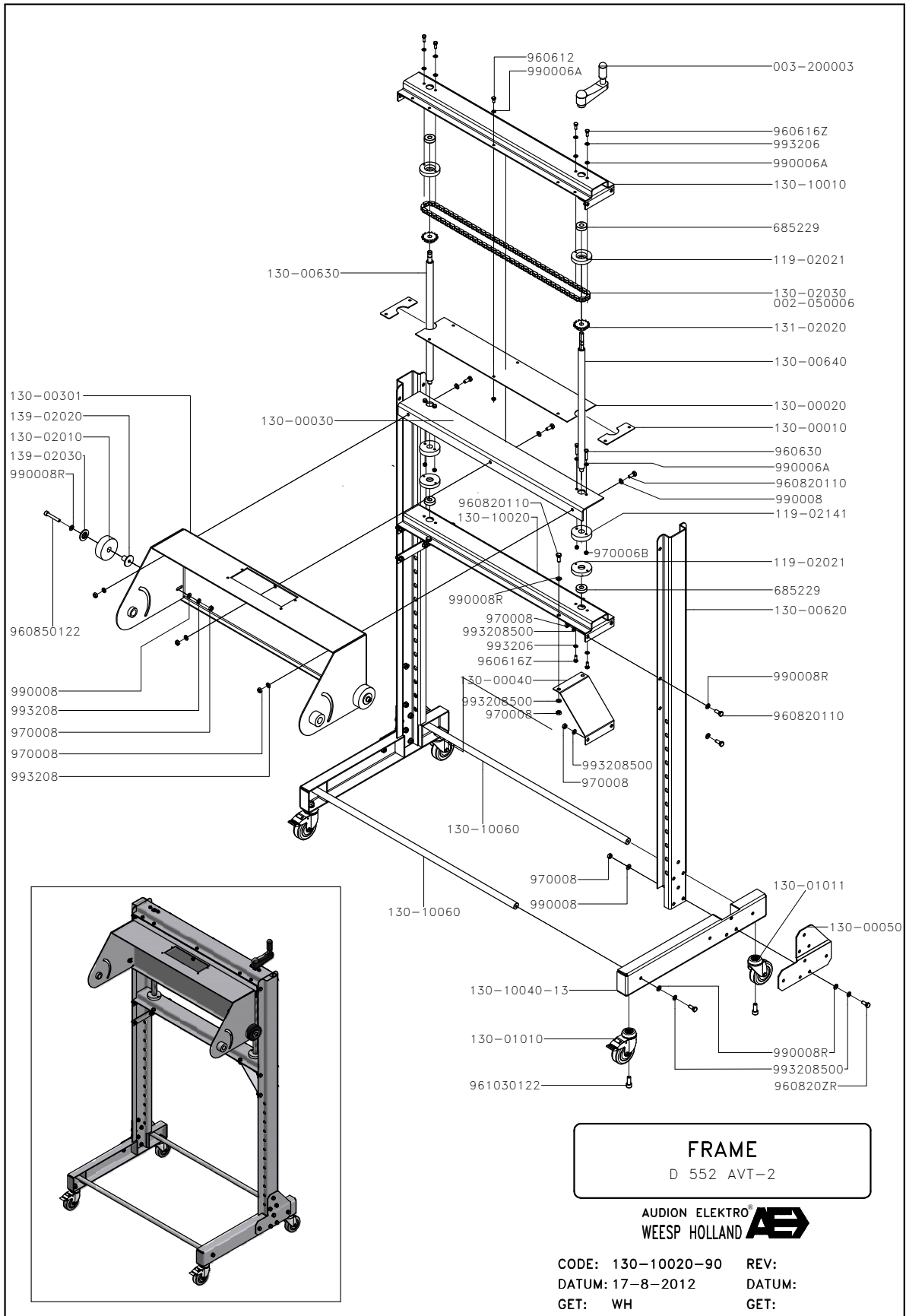

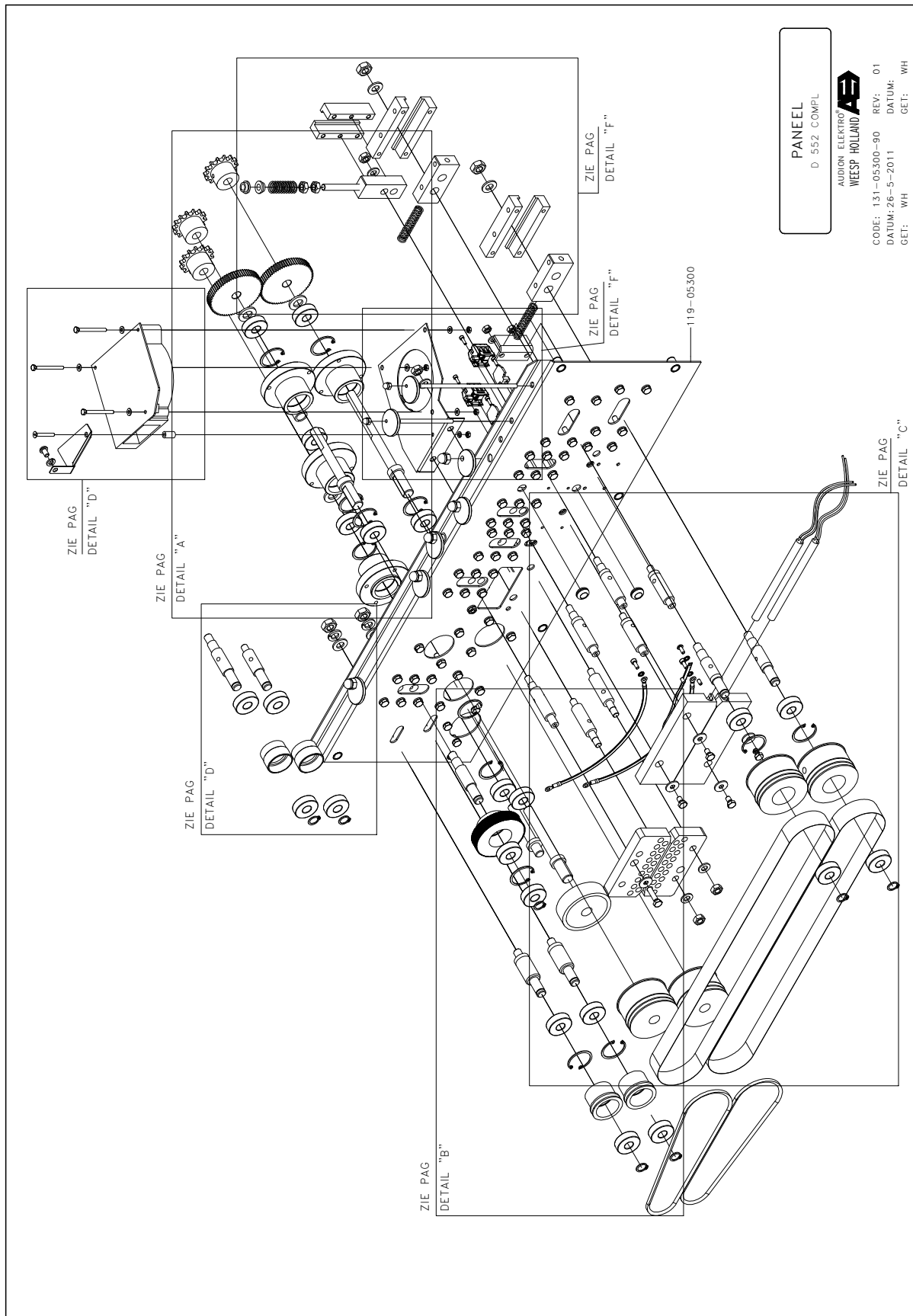

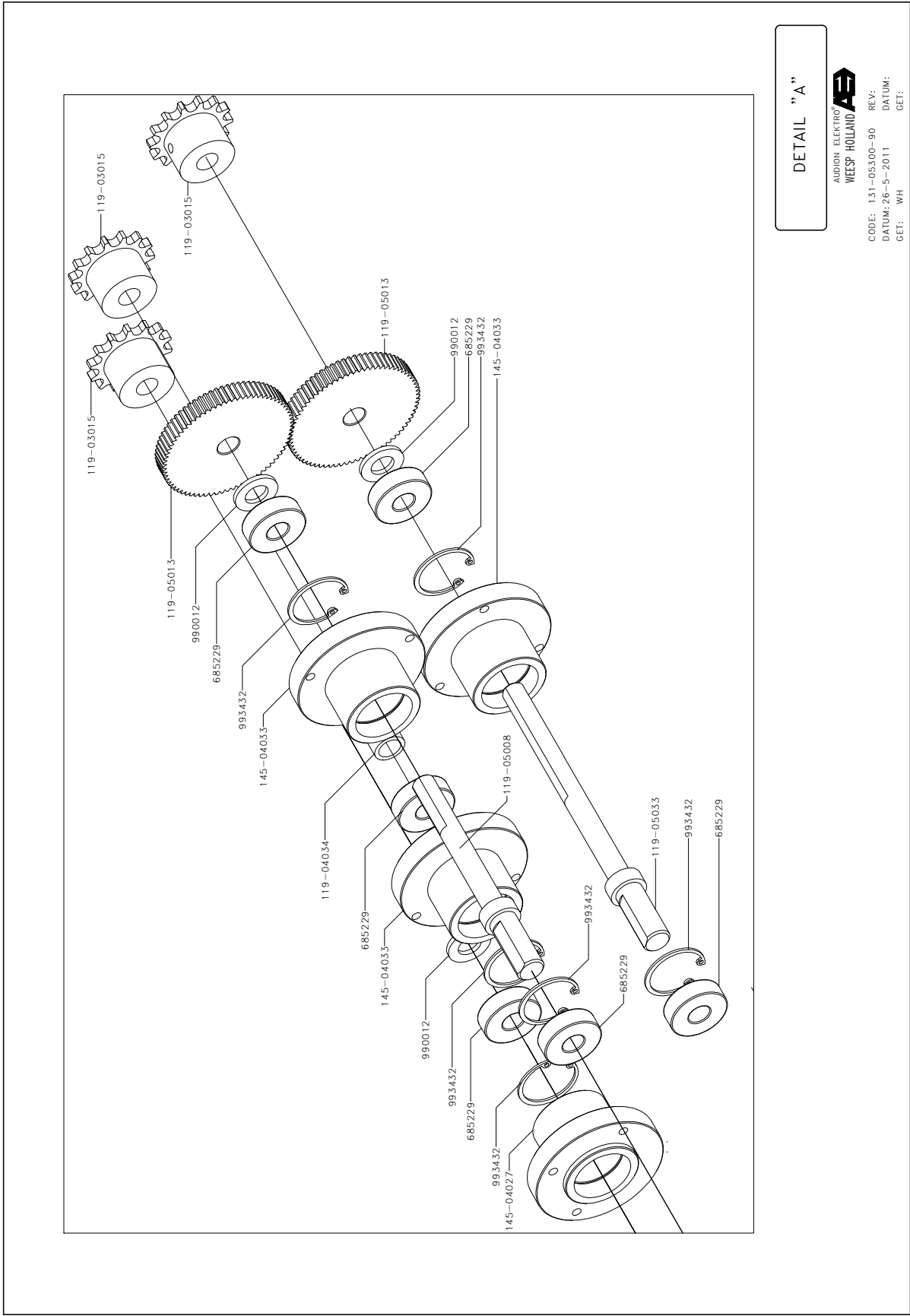

DETAIL "A"

AUDION ELEKTRO
WEESP HOLLAND **AE**

CODE: 131-05300-90 REV:
DATUM: 26-5-2011 DATUM:
GET: WH GET:

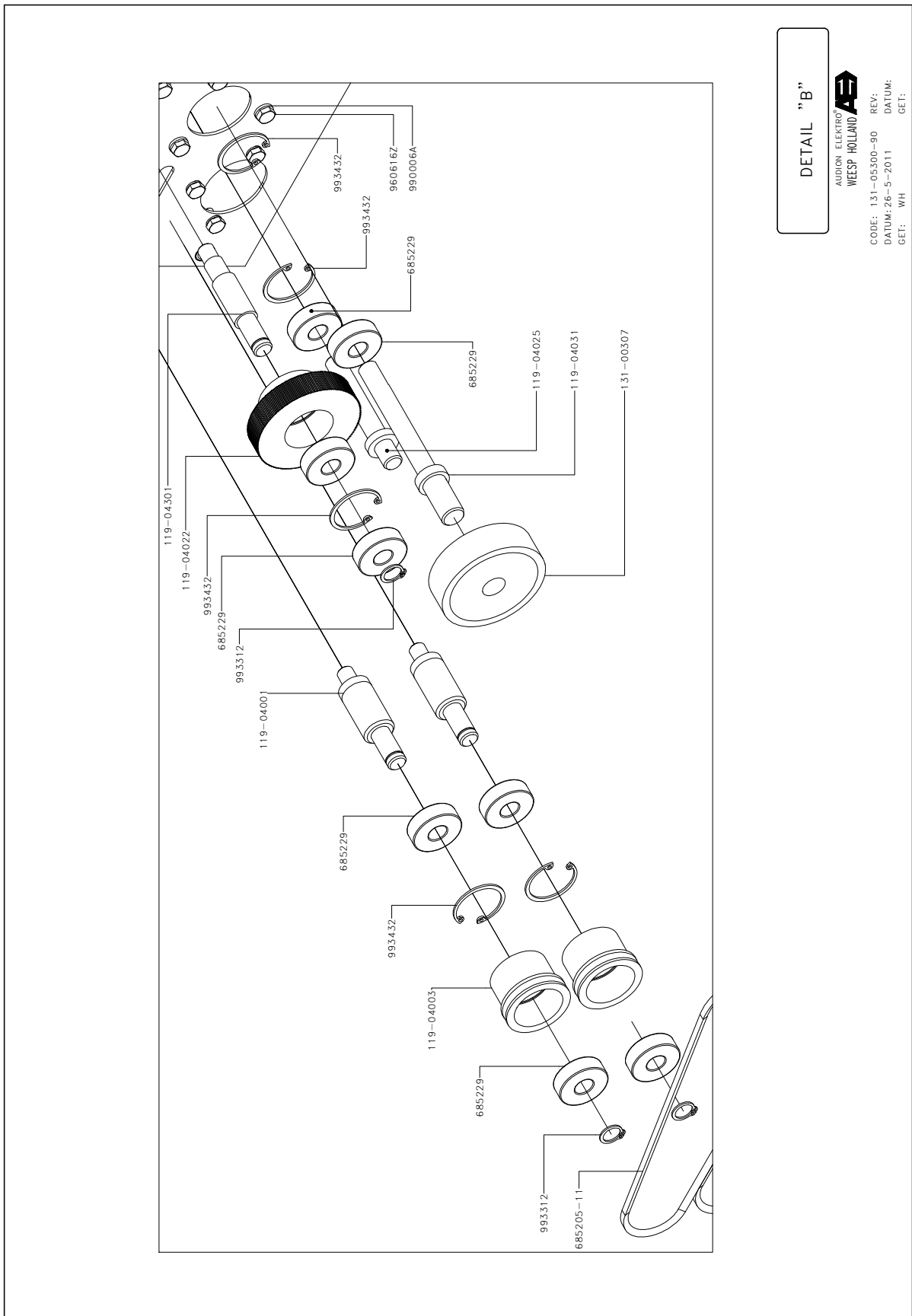

DETAIL "B"

AUDION ELEKTRO
WEESP HOLLAND **AE**

CODE: 131-05300-90 REV:
DATUM: 26-5-2011 DATUM:
GET: WH GET:

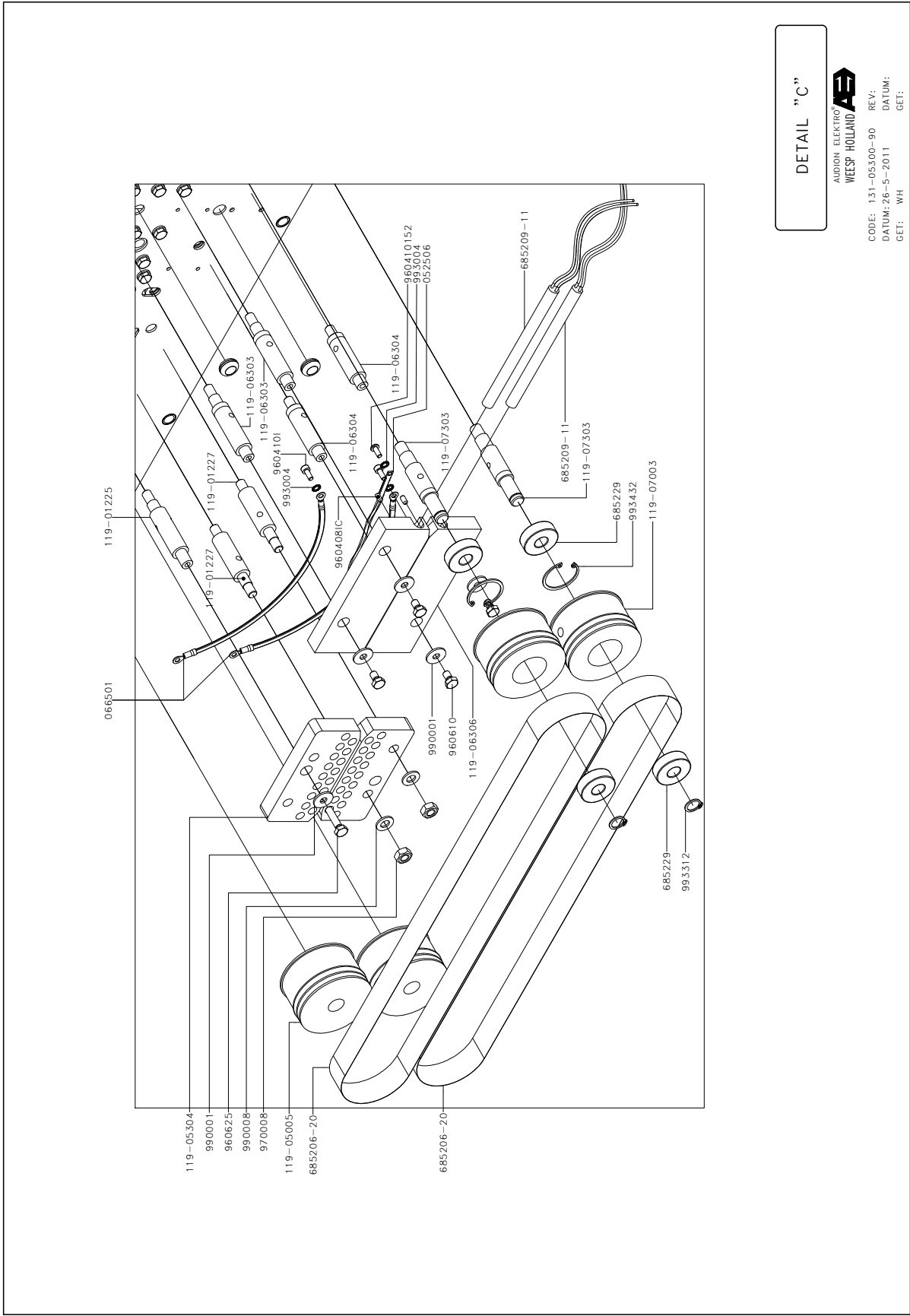

DETAIL "C"

AUDION ELEKTRO
WEESP HOLLAND **AE**

CODE: 131-05300-90 REV:
DATUM: 26-5-2011 DATUM:
GET: WH GET:

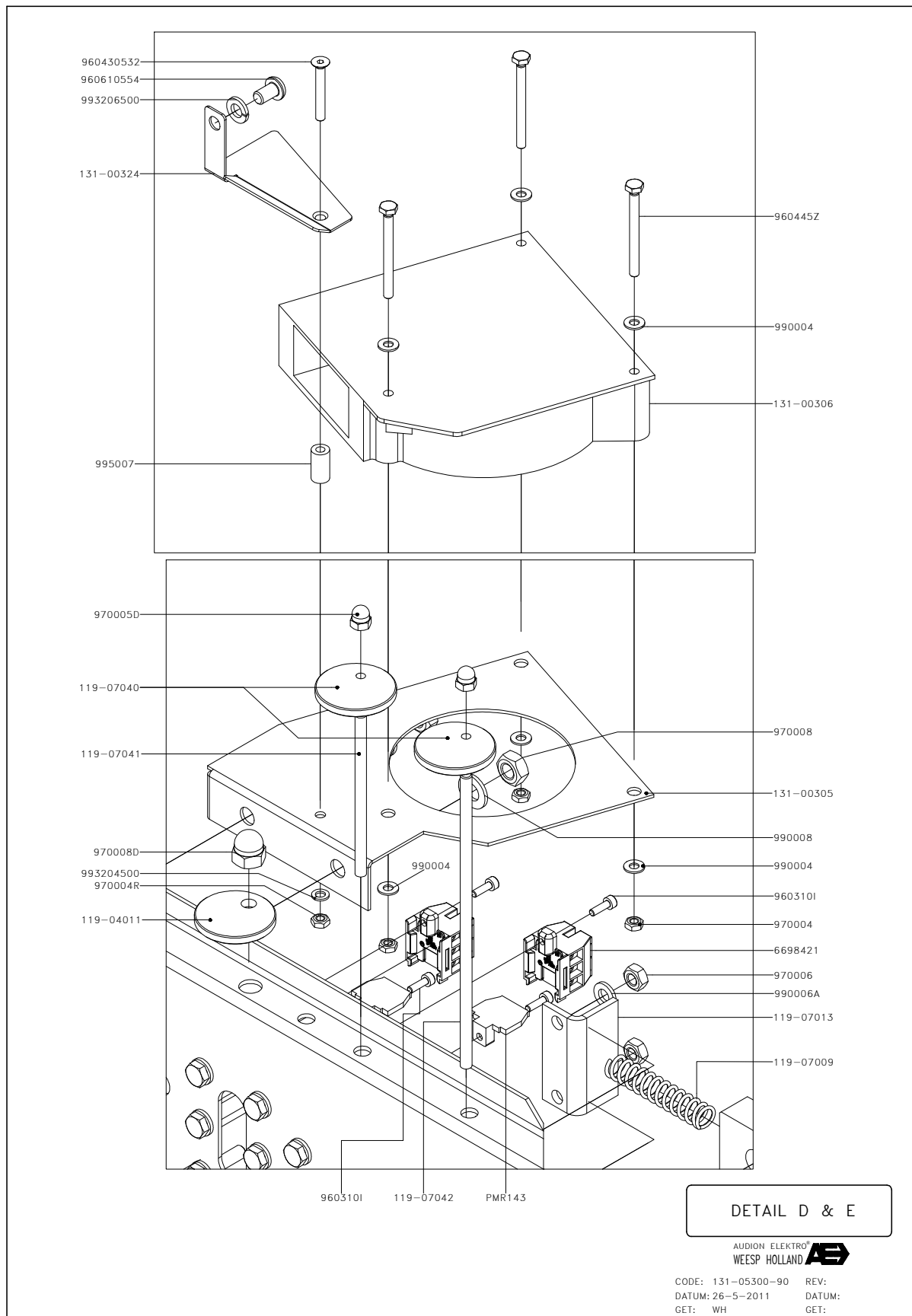

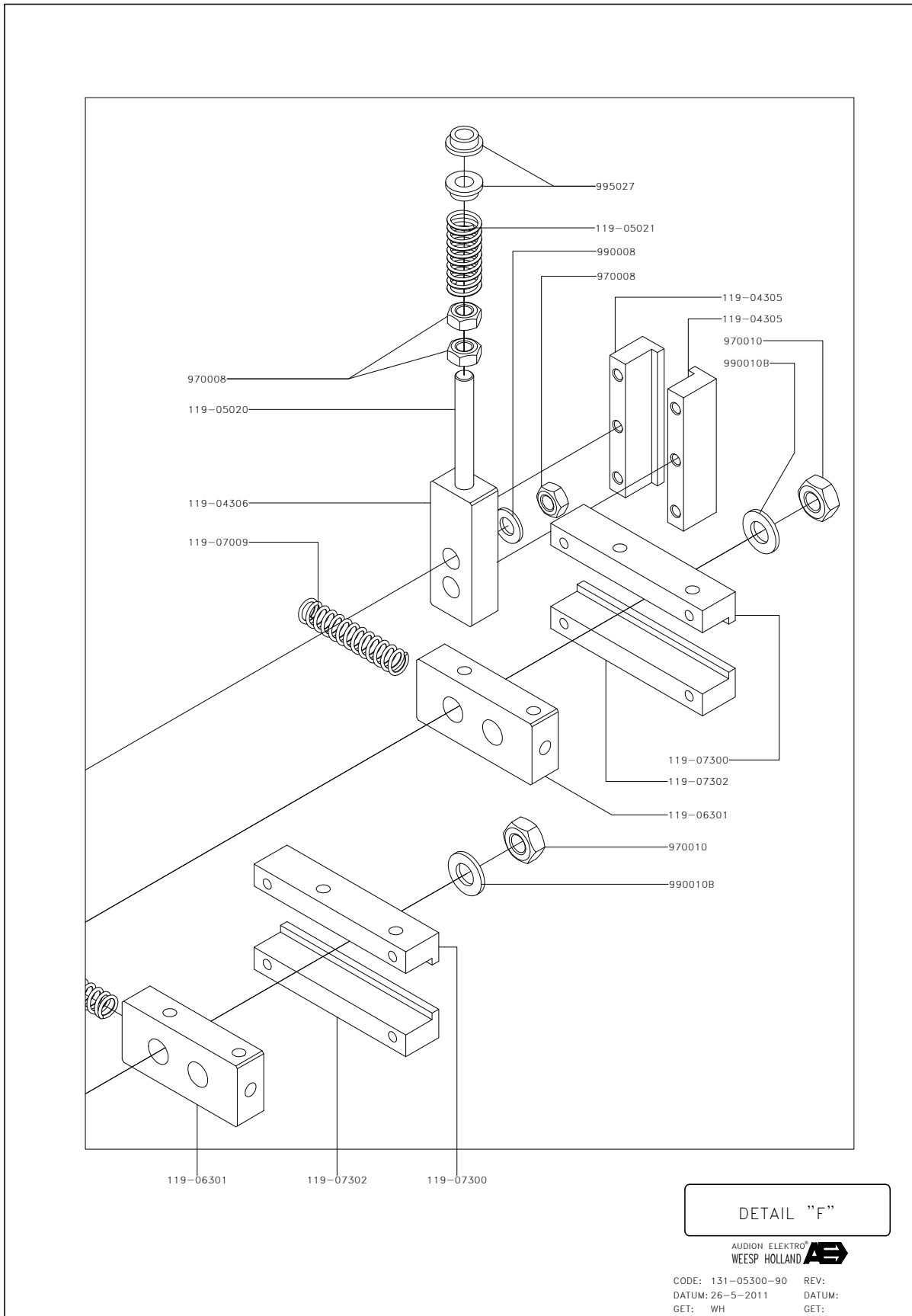

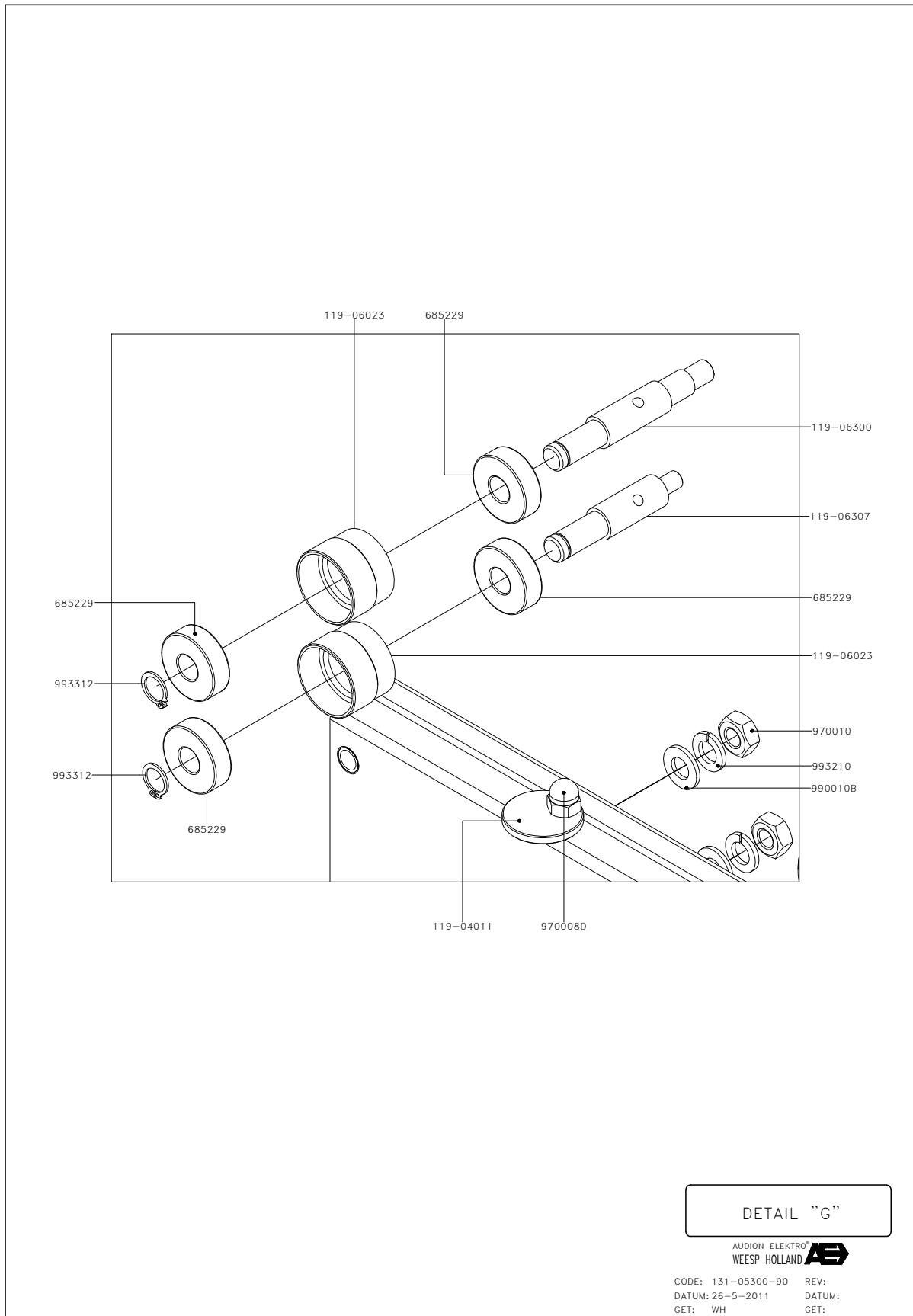

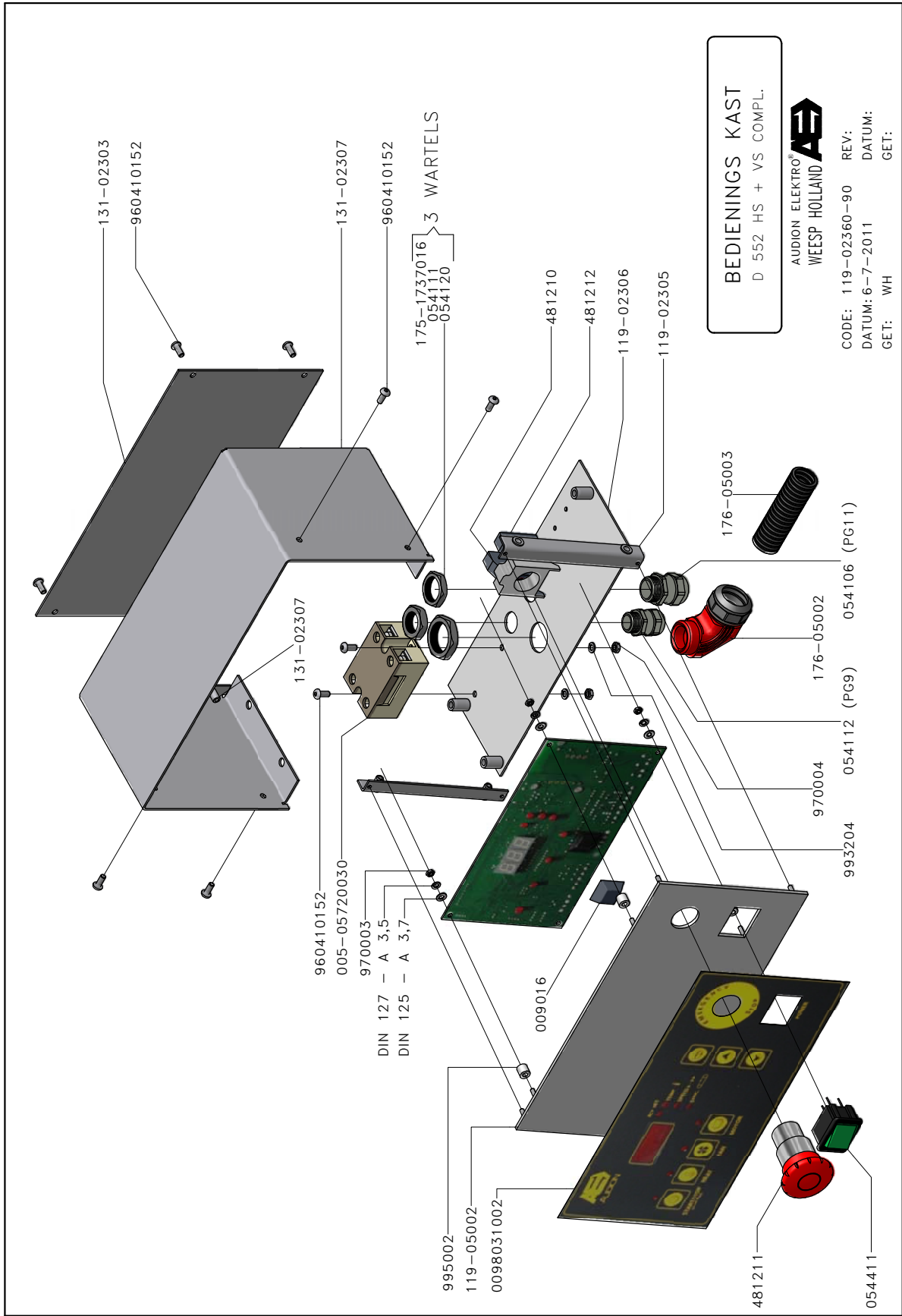

Appendix 4 Log



Always keep a log of all maintenance work.



Refer to Chapter 7 - 'Maintenance' for an overview of the maintenance work to be carried out.



Make a copy of the log and use it to sign off the maintenance work.

Appendix 5

CE declaration

EC-DECLARATION OF CONFORMITY

AUDION ELEKTRO B.V., located at the Hogeweyselaan 235 in
Weesp, The Netherlands

herewith declares that the

ALL IN SEALER 552

Type:

D 552 AV(T)-2

- is in conformity with the provisions of the following EEC directives:
2006/42/EC Machine Directive ; 2004/108/EC EMC-Directive ;
- and that the following (parts/clauses of) harmonized standards have been
applied:
EN-ISO 12100; EN-ISO 13732-1; EN-ISO 13850; EN 1037+A1; EN-IEC
60204-1;

Weesp, 28-1-2013

E.Tangelder
Director



PGR139B

Audion Elektro BV
Hogeweyselaan 235
1382 JL Weesp
The Netherlands
Tel +31 (0)294 491717
Fax +31 (0)294 491761
Email holland@audion.nl
www.audion.com

Represented by: